



# **Biomimetic Robotic Fishes**

*presented by*

**Mr. Heng Yeow Kiat, Ms. Huang YunYun**

School of Mechanical and Aerospace Engineering

30<sup>th</sup> November – 2<sup>nd</sup> December 2006

2<sup>nd</sup> International Capstone Design Fair

Taegue, Korea



# Research Team Members

**Dr. Low Kin Huat (MAE), Project Supervisor**

**Dr. Gerald Seet (MAE)**

**Dr. Chen I-Ming (MAE)**

**Ms. Poea Hui Fong**

**Mr. Christian Eigenmann**



# Contents

- Introduction
- Fish Morphology
- Fish Swimming Modes
  - MPF Swimming Mode
    - Median Fin Design
    - Stingray Robot
    - Knifefish Robot
  - BCF Swimming Mode
    - Caudal Fin Design
    - Arowana Robot
- Future Applications & Conclusion



# Introduction

- Trend towards biomimetic robot; to learn from *nature*
- Simulate earth's greatest examples of success, living organisms
- An alternative solution for underwater vehicles - less *noise & pollution*
- Function better in the real world



# Fish Morphology

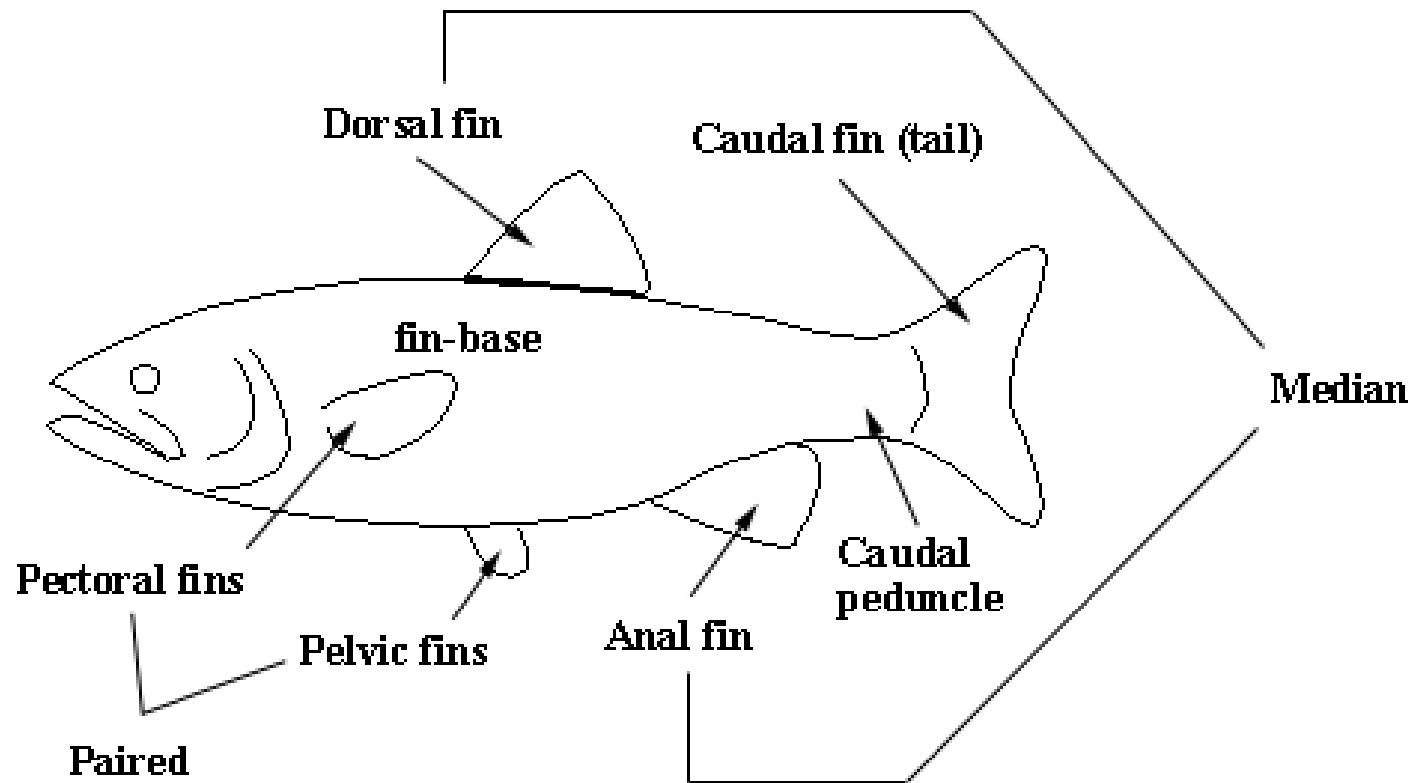

# Fish Swimming Modes

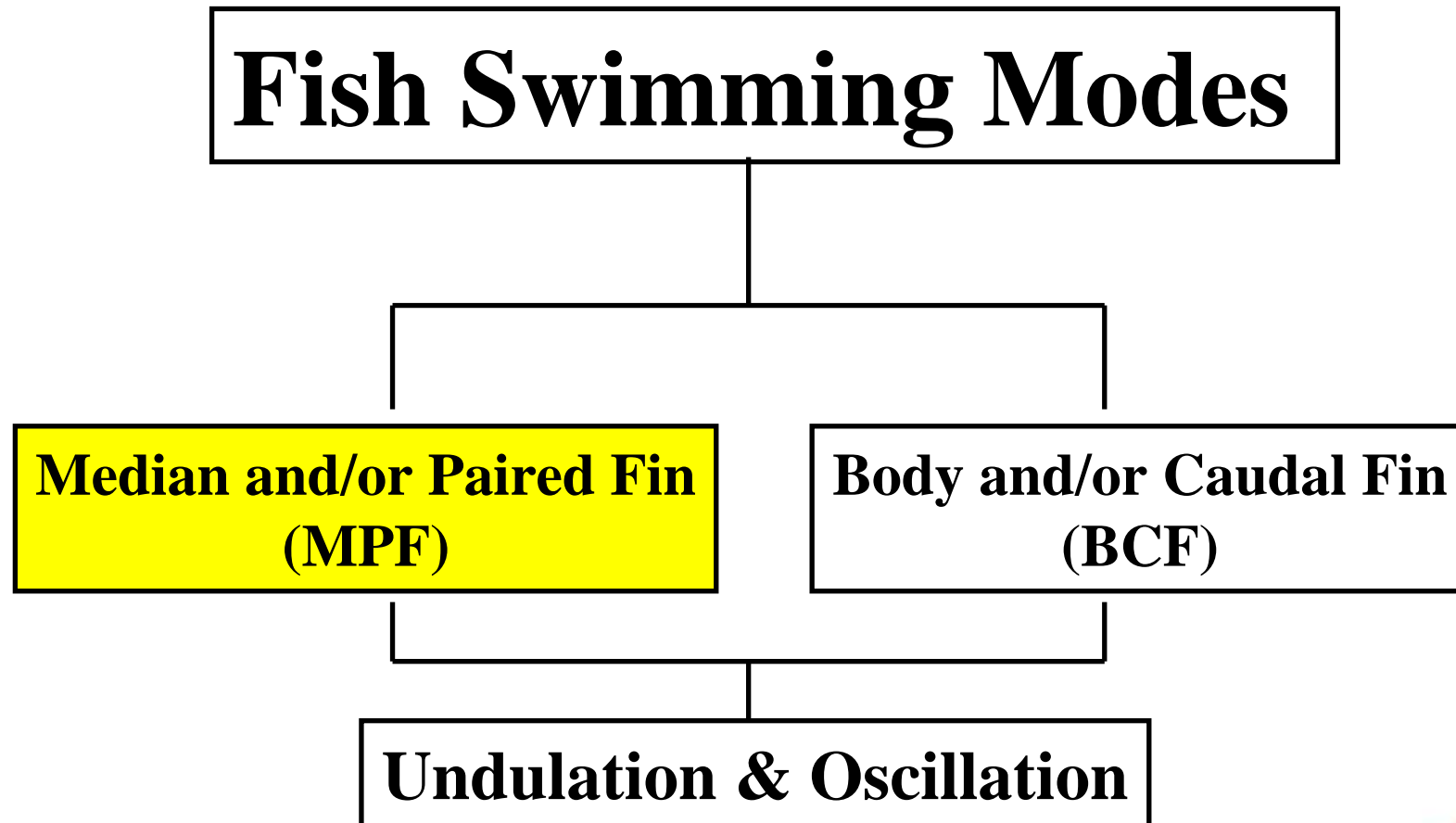

# Median Paired Fin (MPF) Swimming Mode

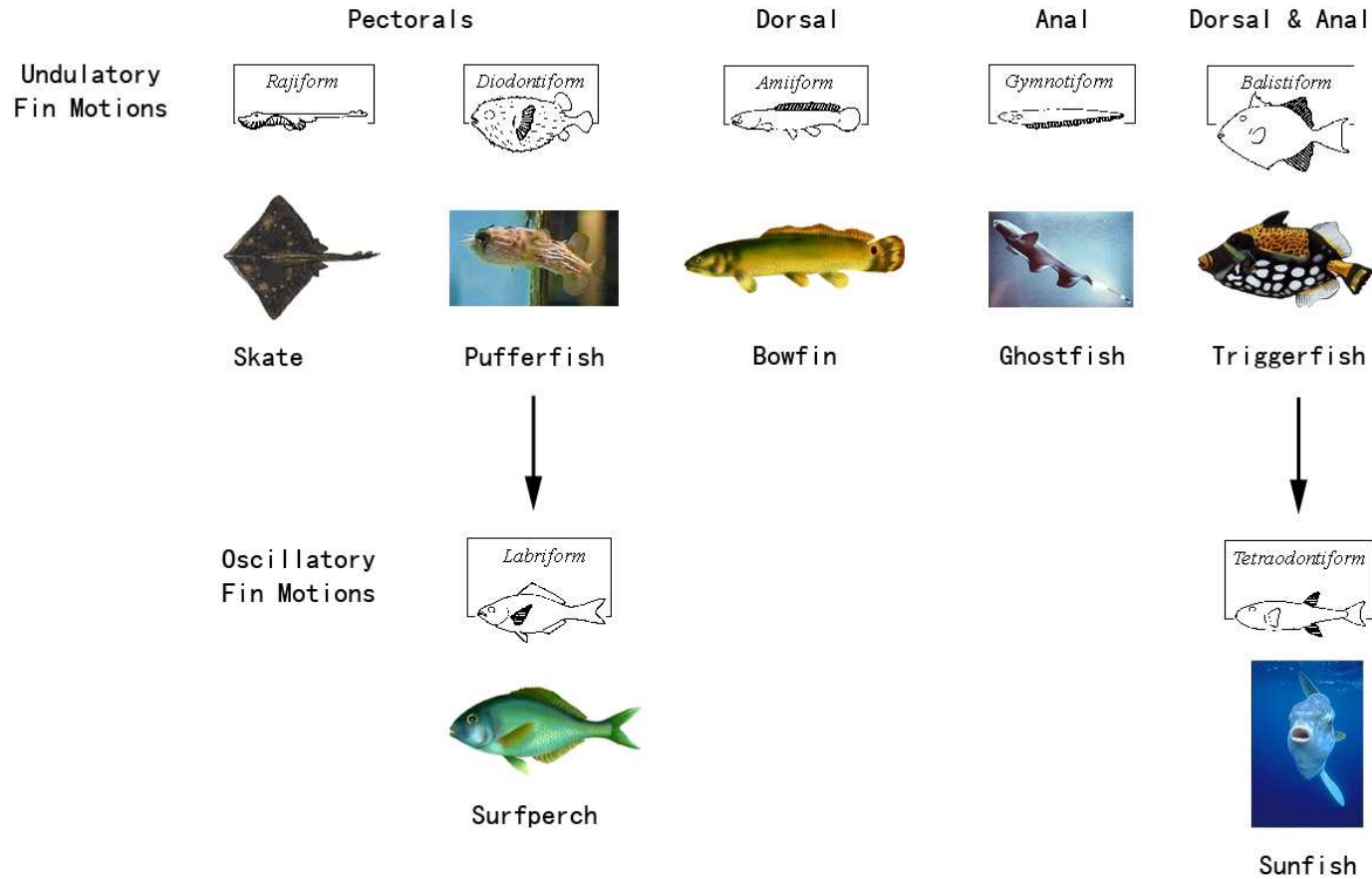

# Modeling of Mechanical Fin

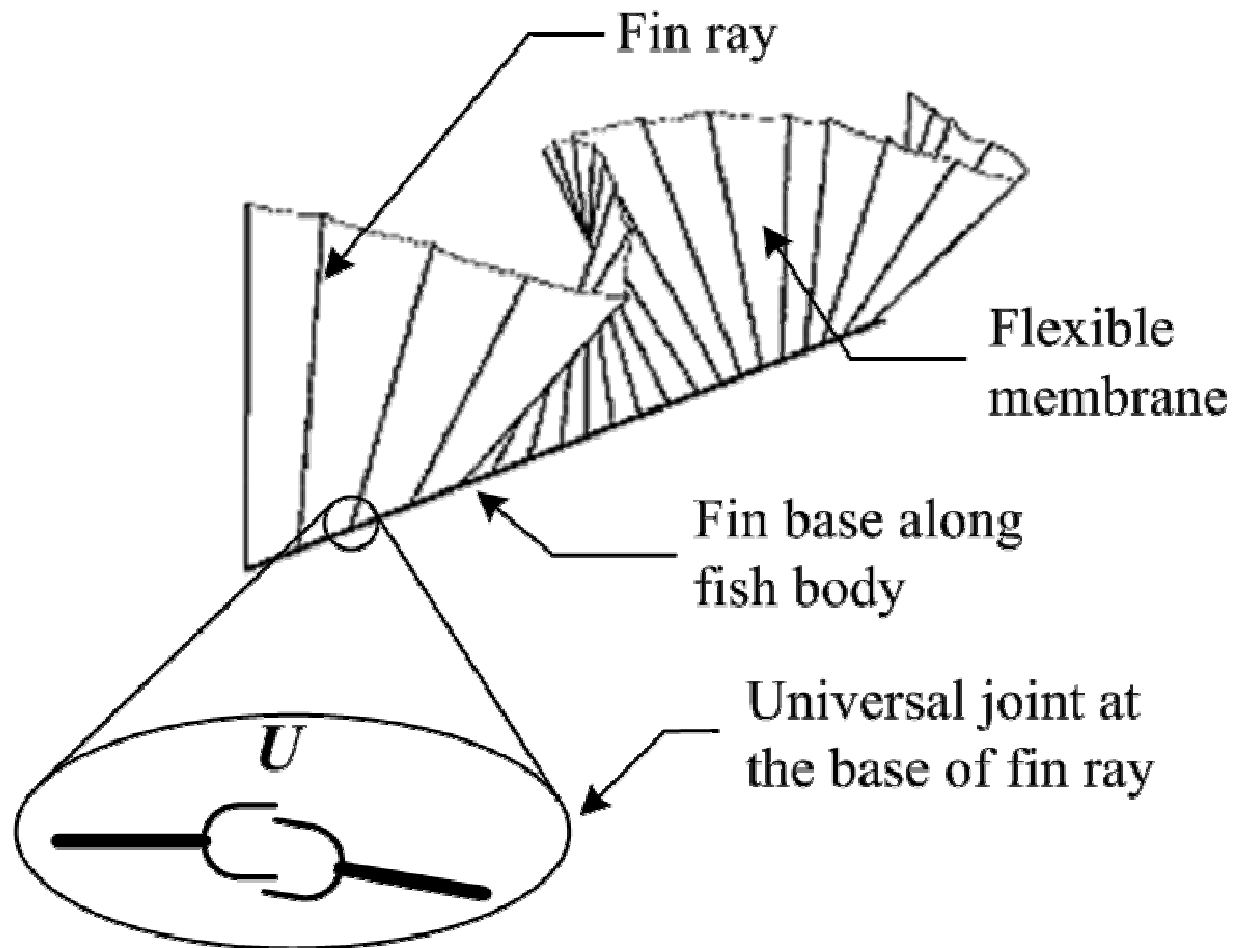

# Median Fin Design

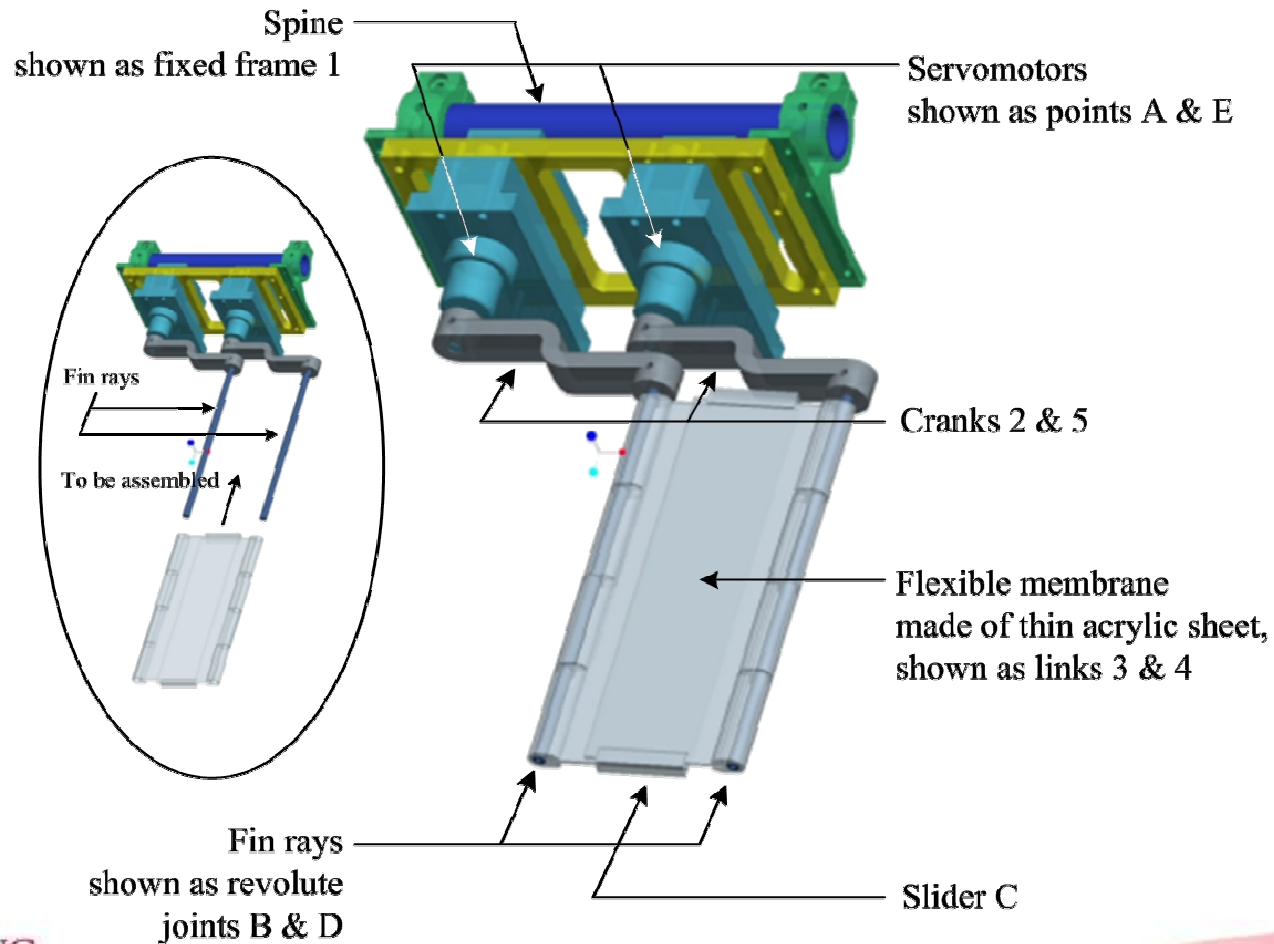

# CAD Model

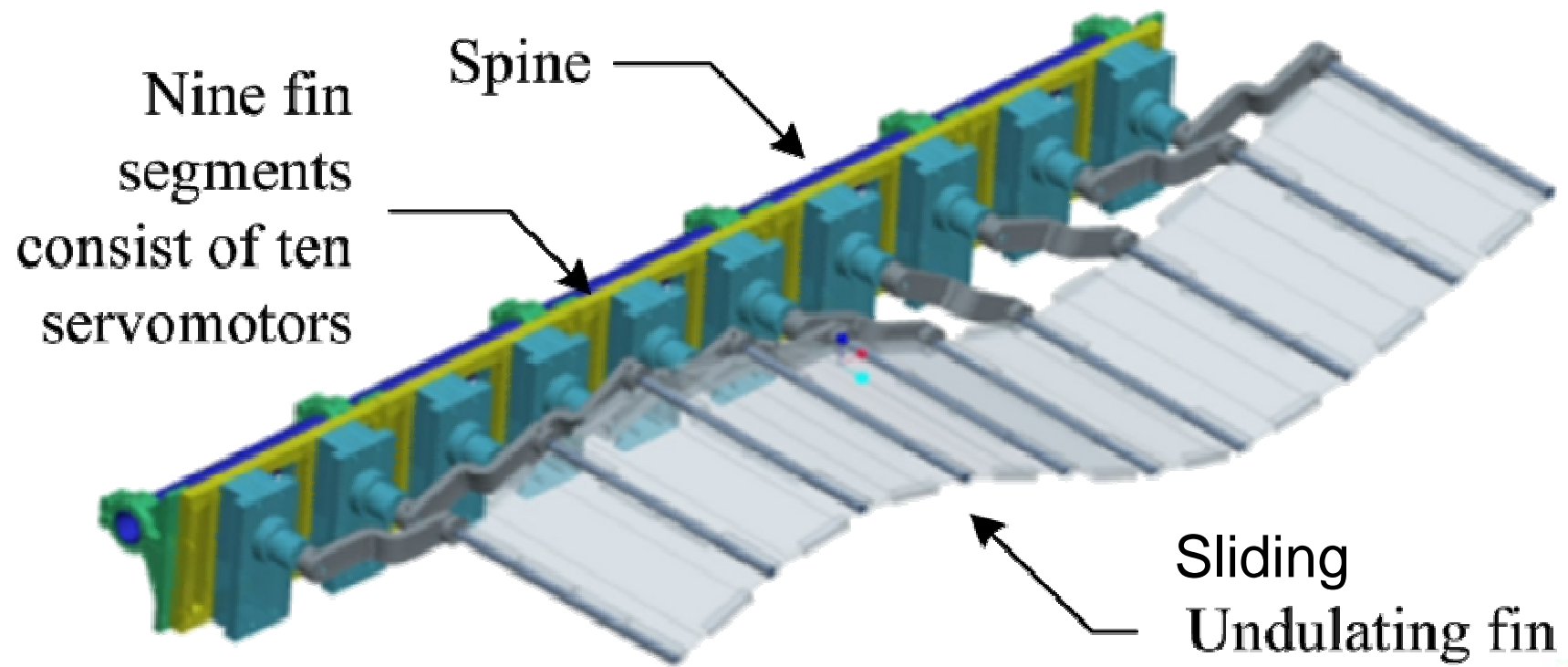

# Stingray



# Stingray Robot

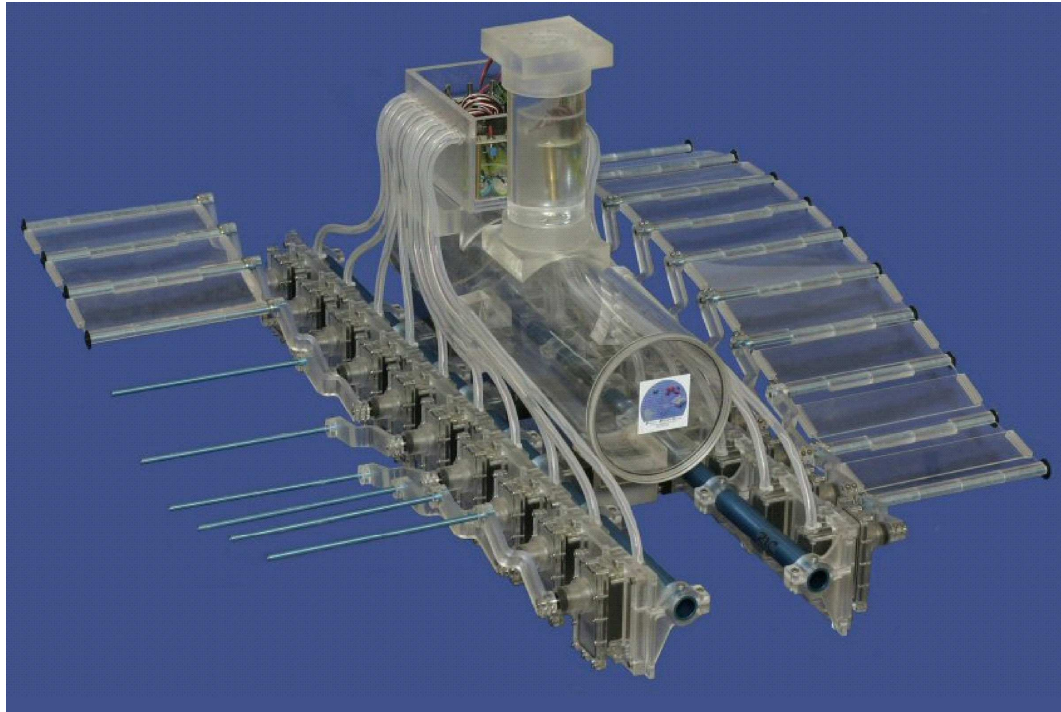

# Undulatory Fin Motion

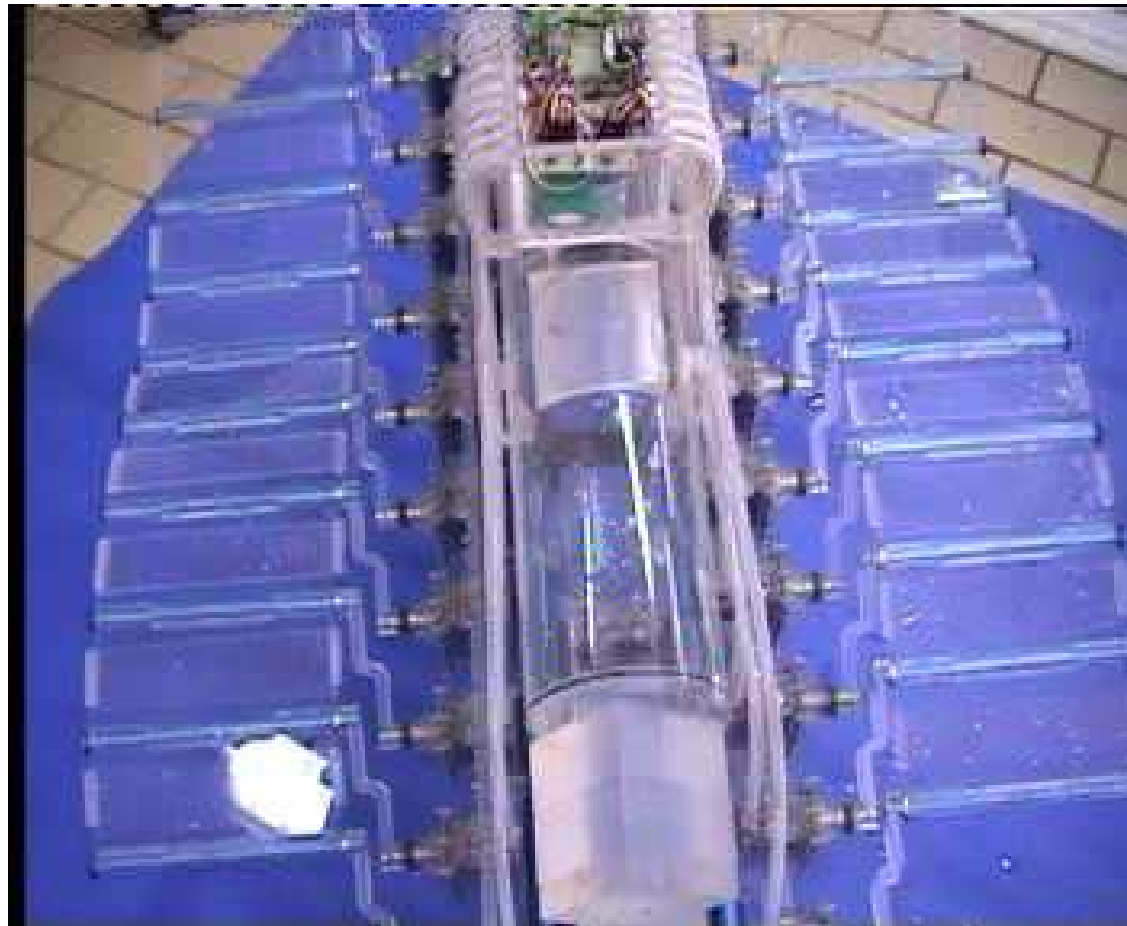

# Quiet and Environmental Friendly Propulsor



# Stingray Robot – Swimming Pool Test



# Experimental Results (Swimming Efficiency)

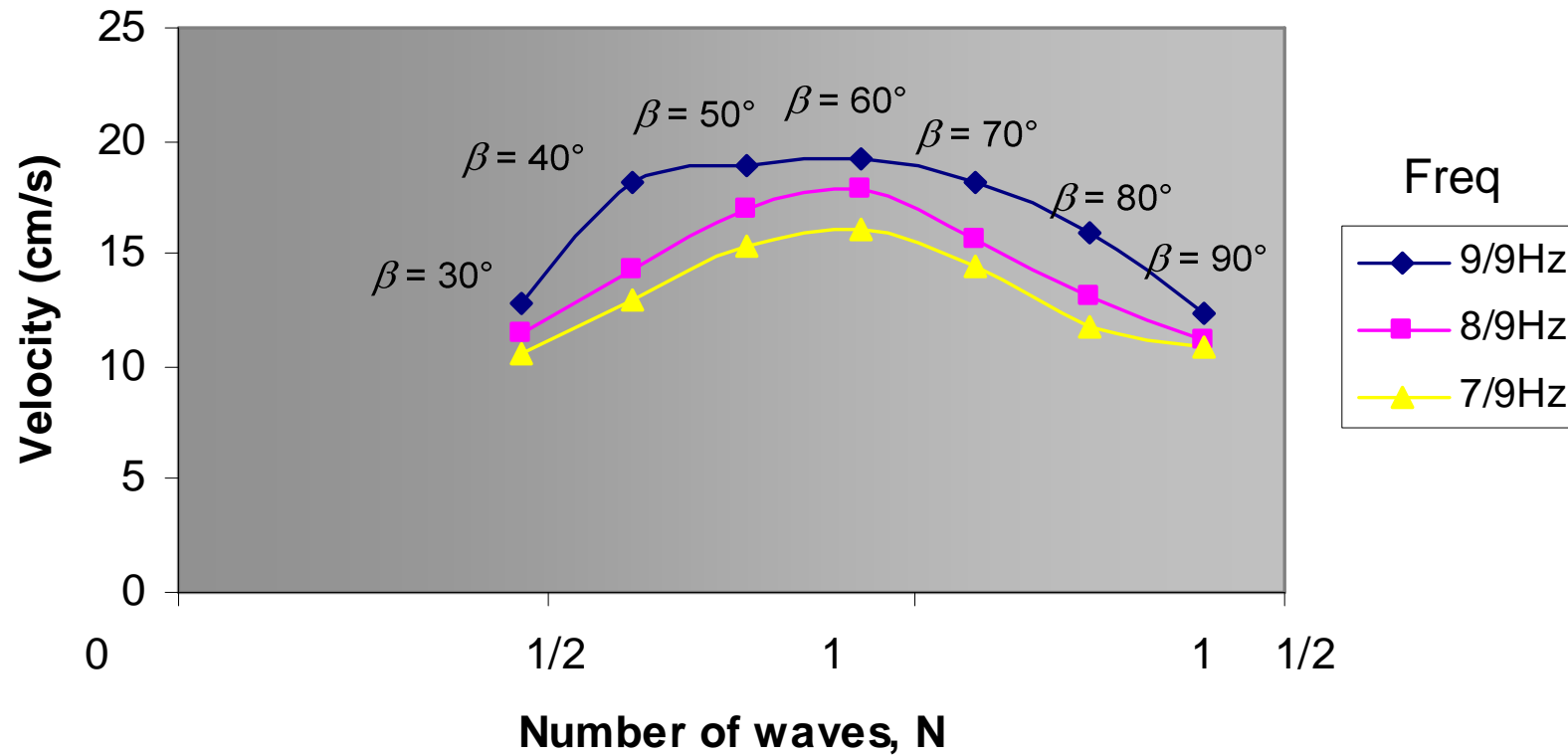

# Buoyancy Control in Fish

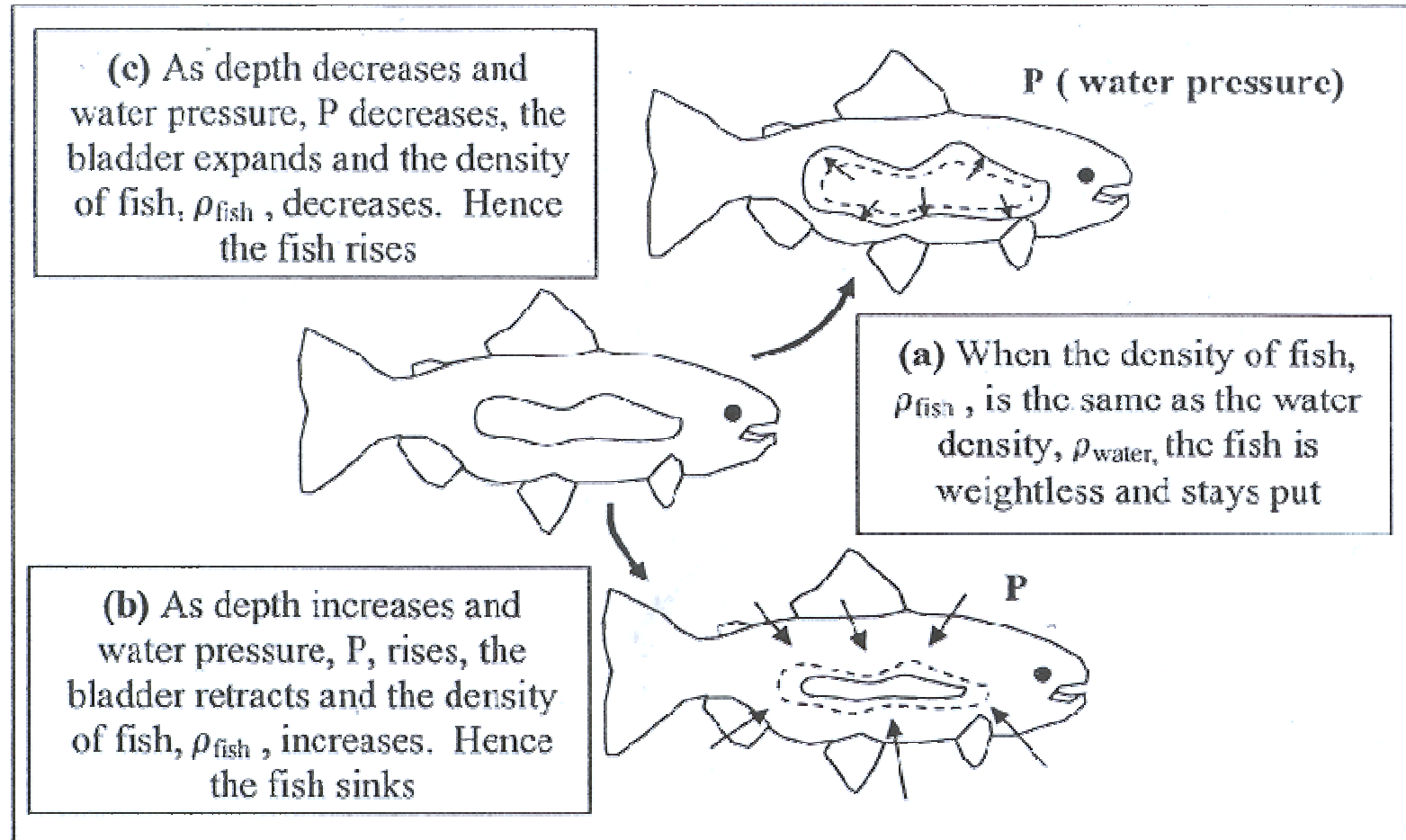

# Buoyancy Tank - Design

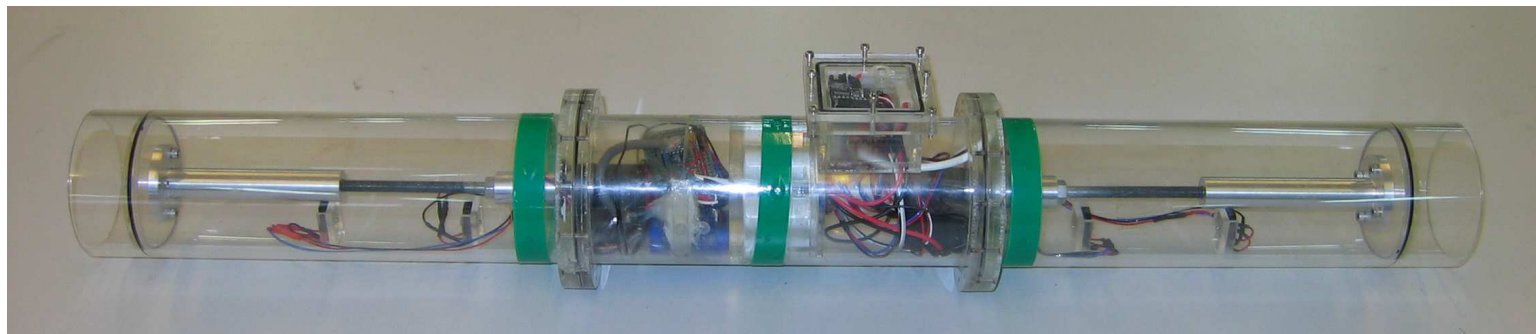
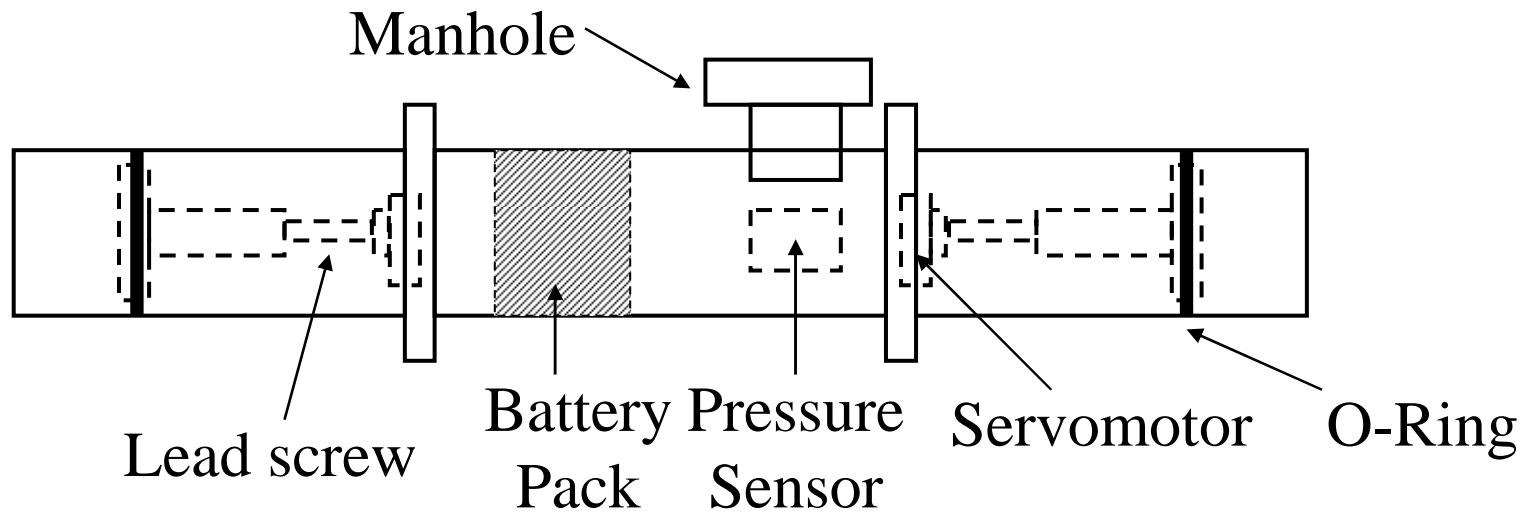

# Buoyancy Tank – Operating Principal

Depth Control Operation

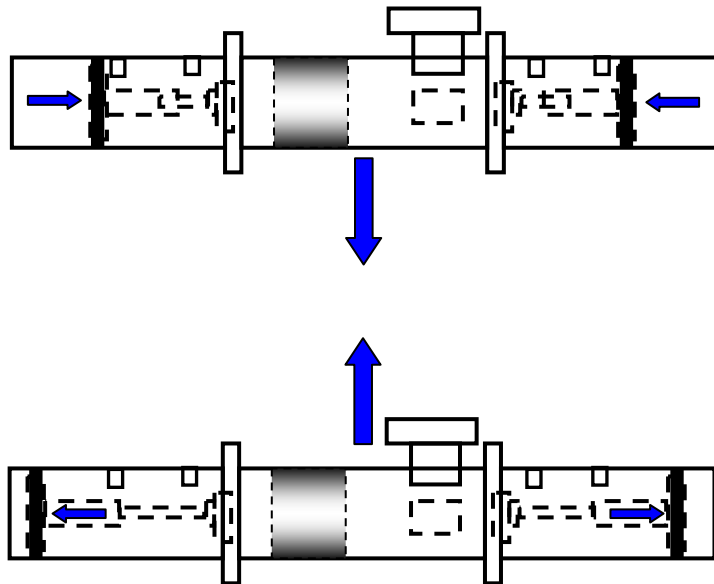

Tilt Control Operation

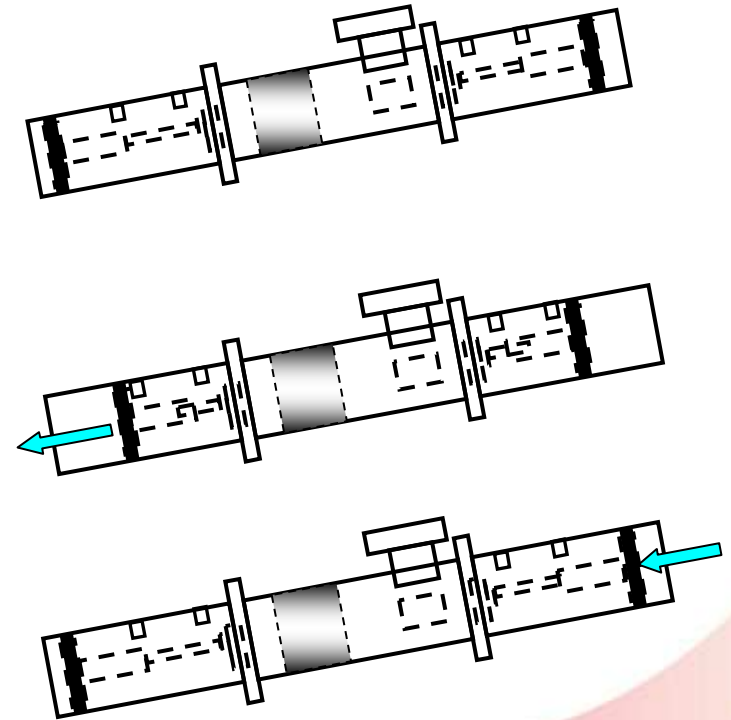

# Black Ghost Knife-fish



# Knifefish Robot

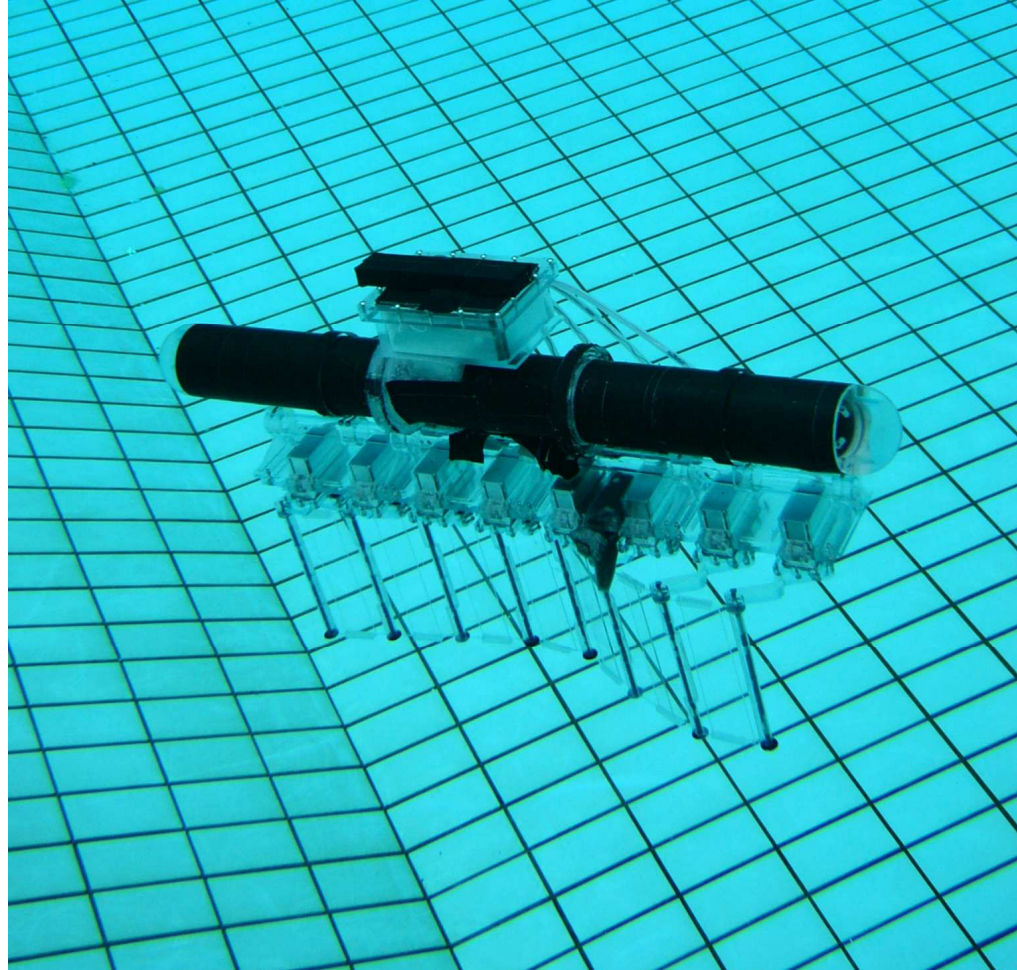

# Knifefish Robot – Lab and Swimming Pool Test

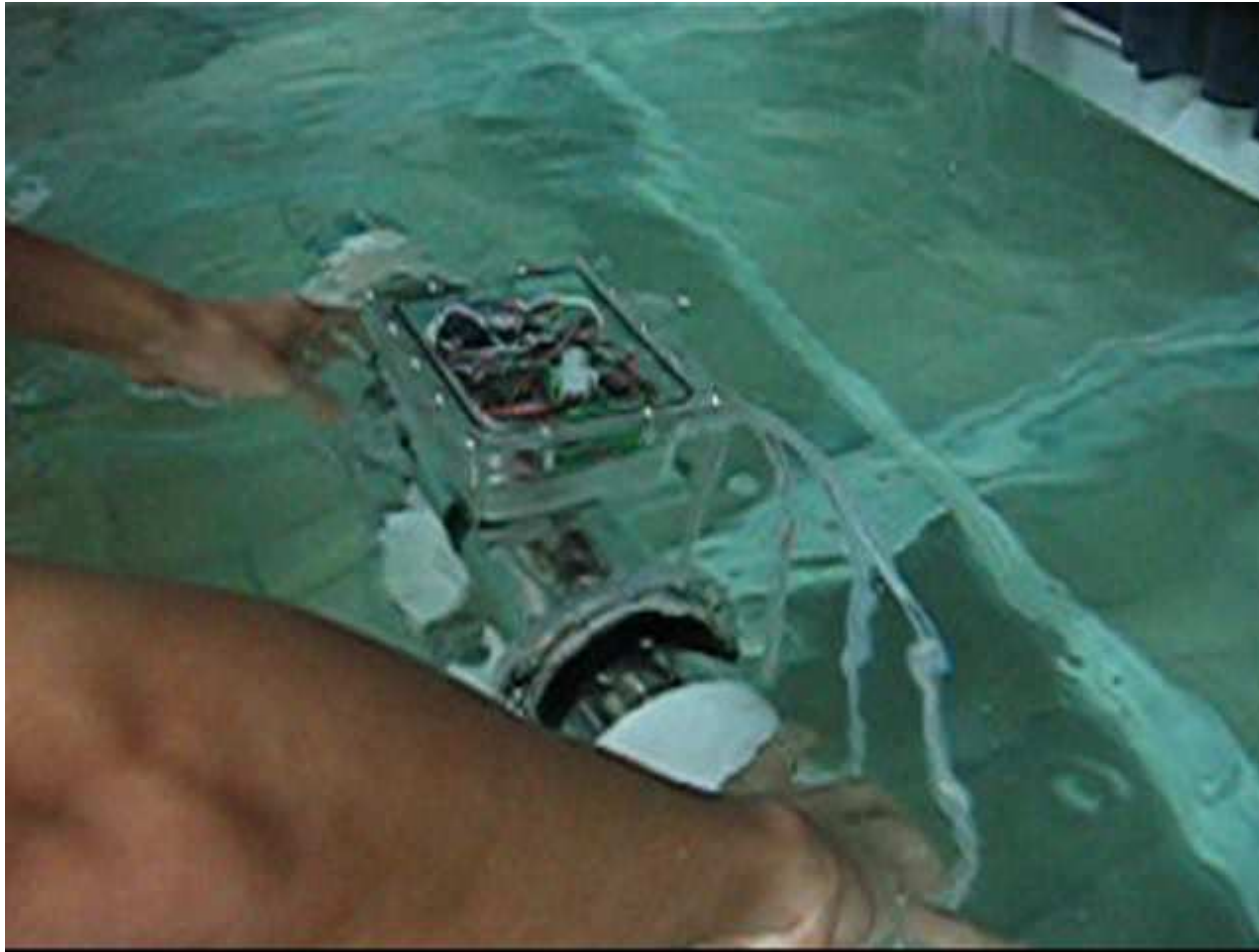

# Experimental Results

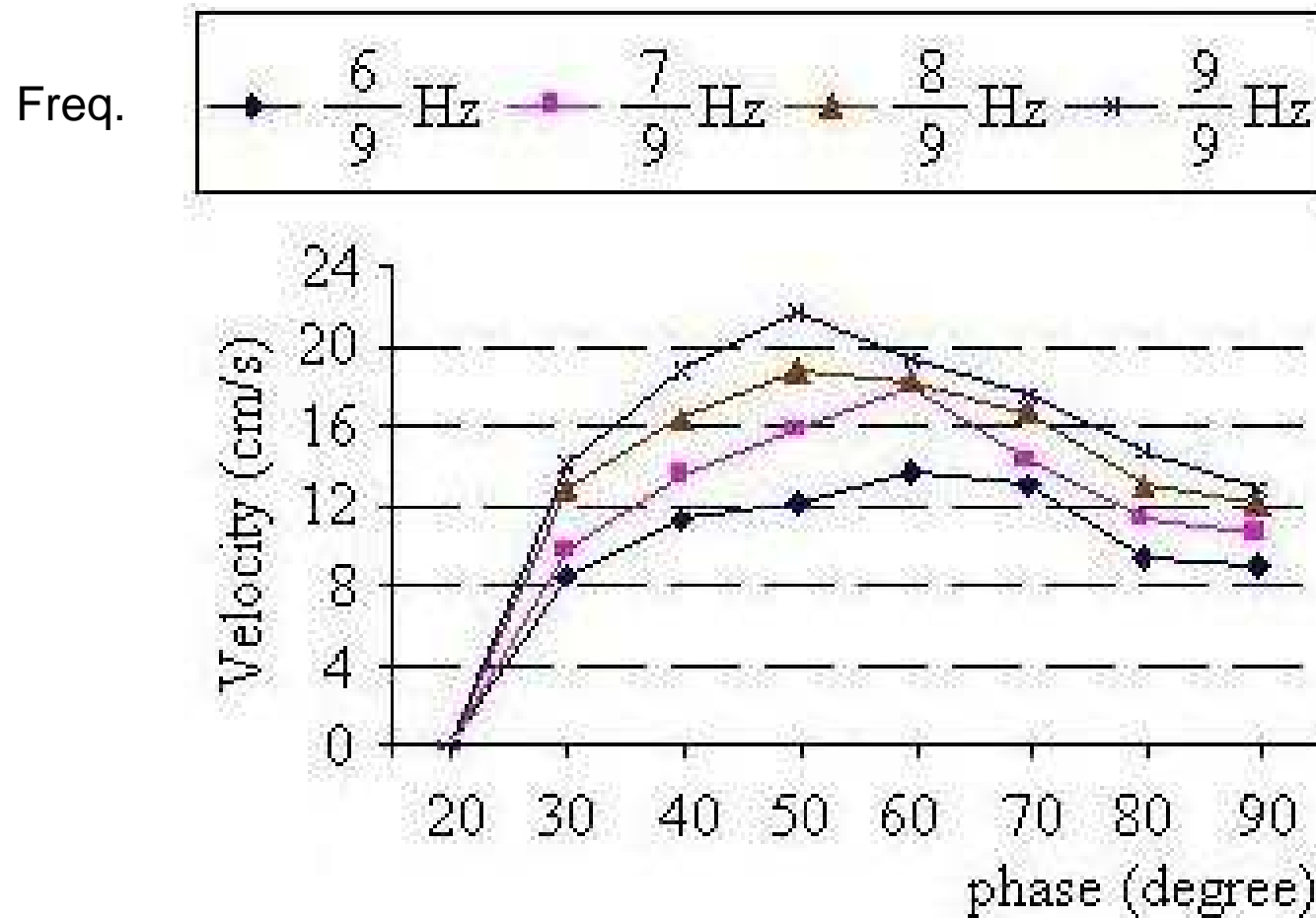

# Fish Swimming Modes

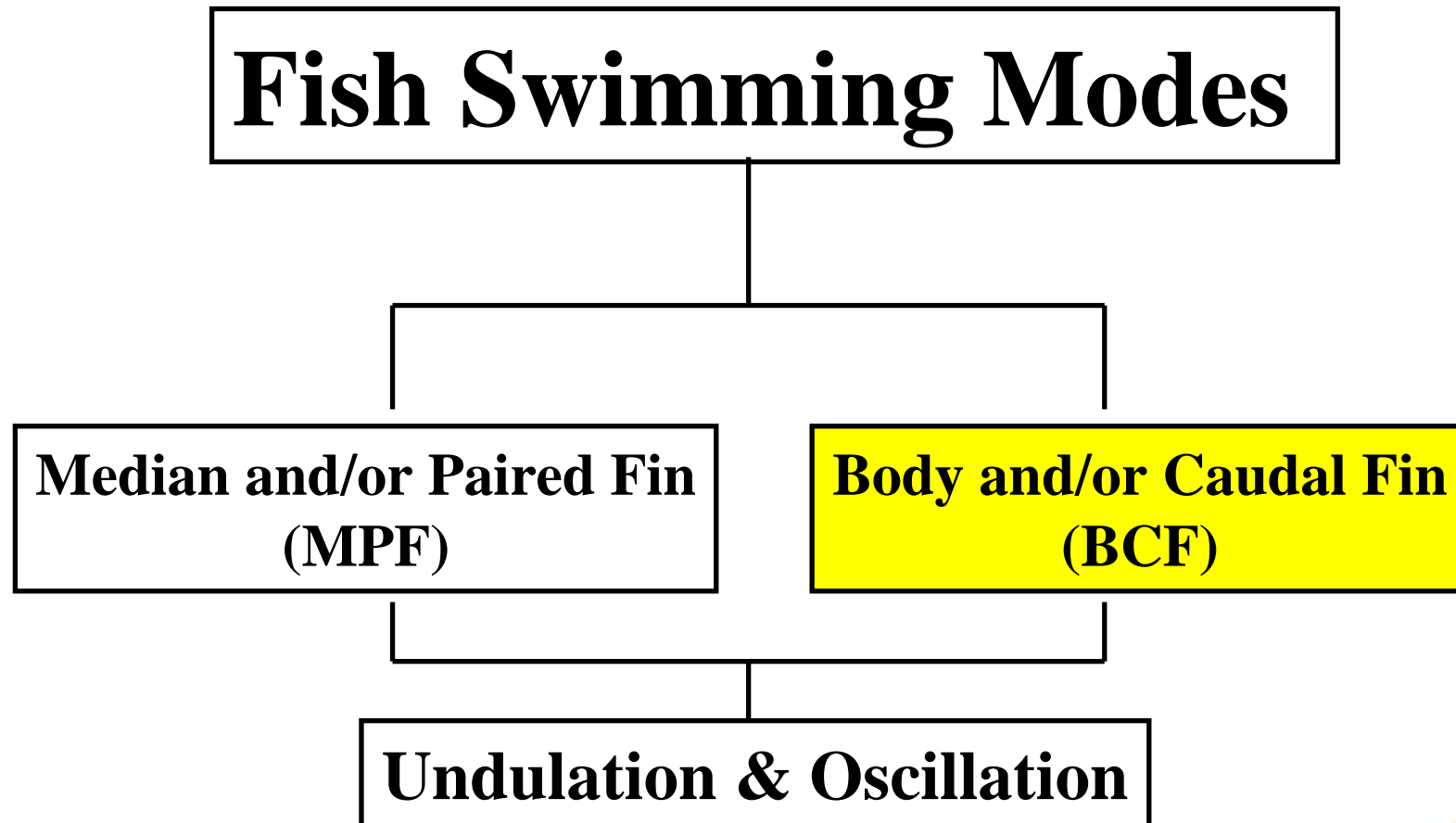

# Body Caudal Fin (BCF) Swimming Mode

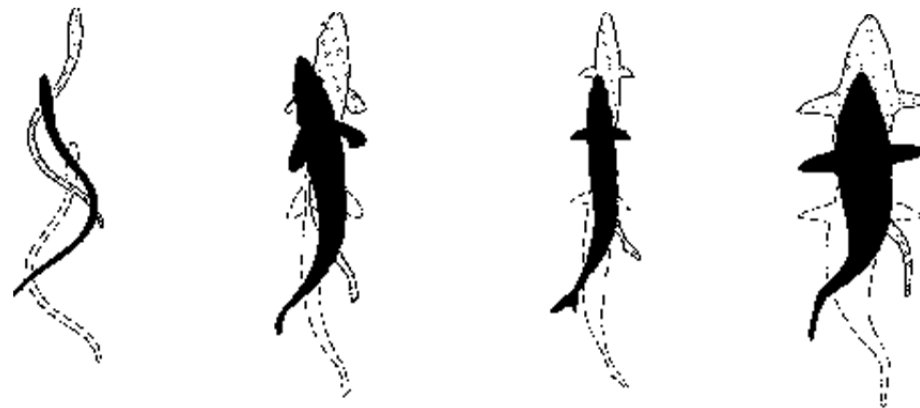
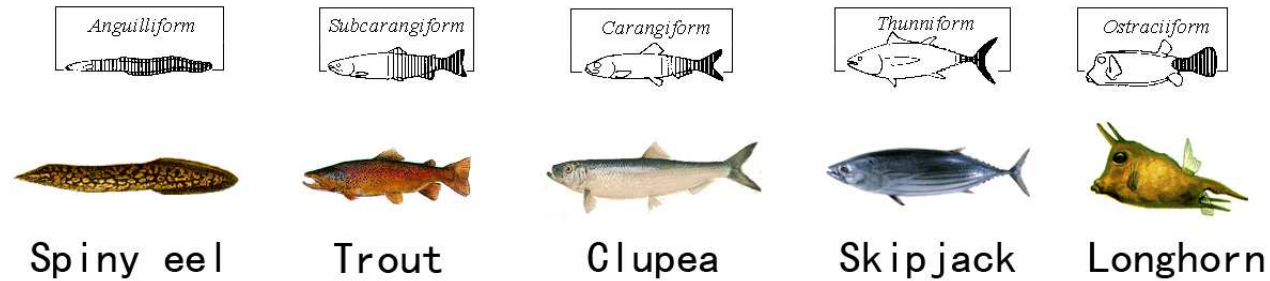

# CAD Model – Caudal Fin Design

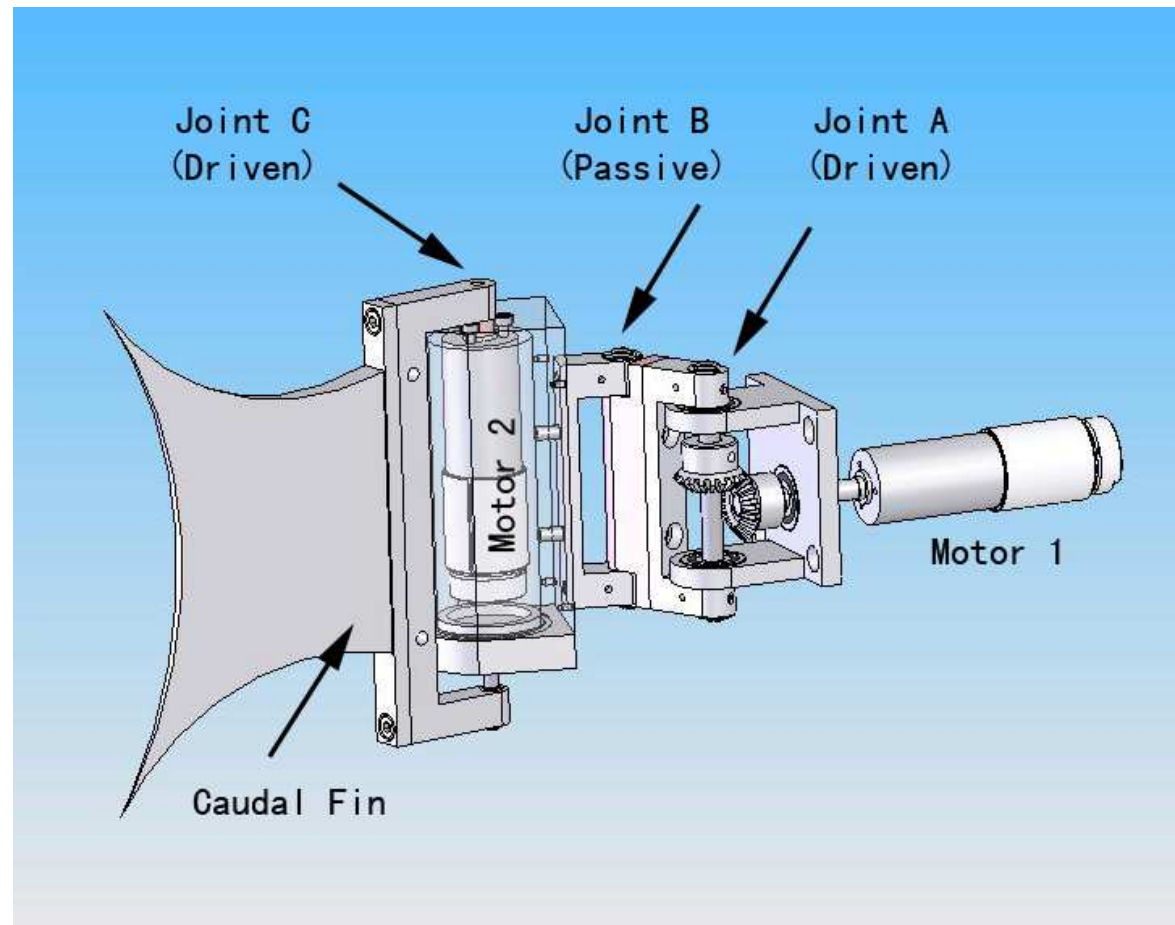

# Conceptual Design

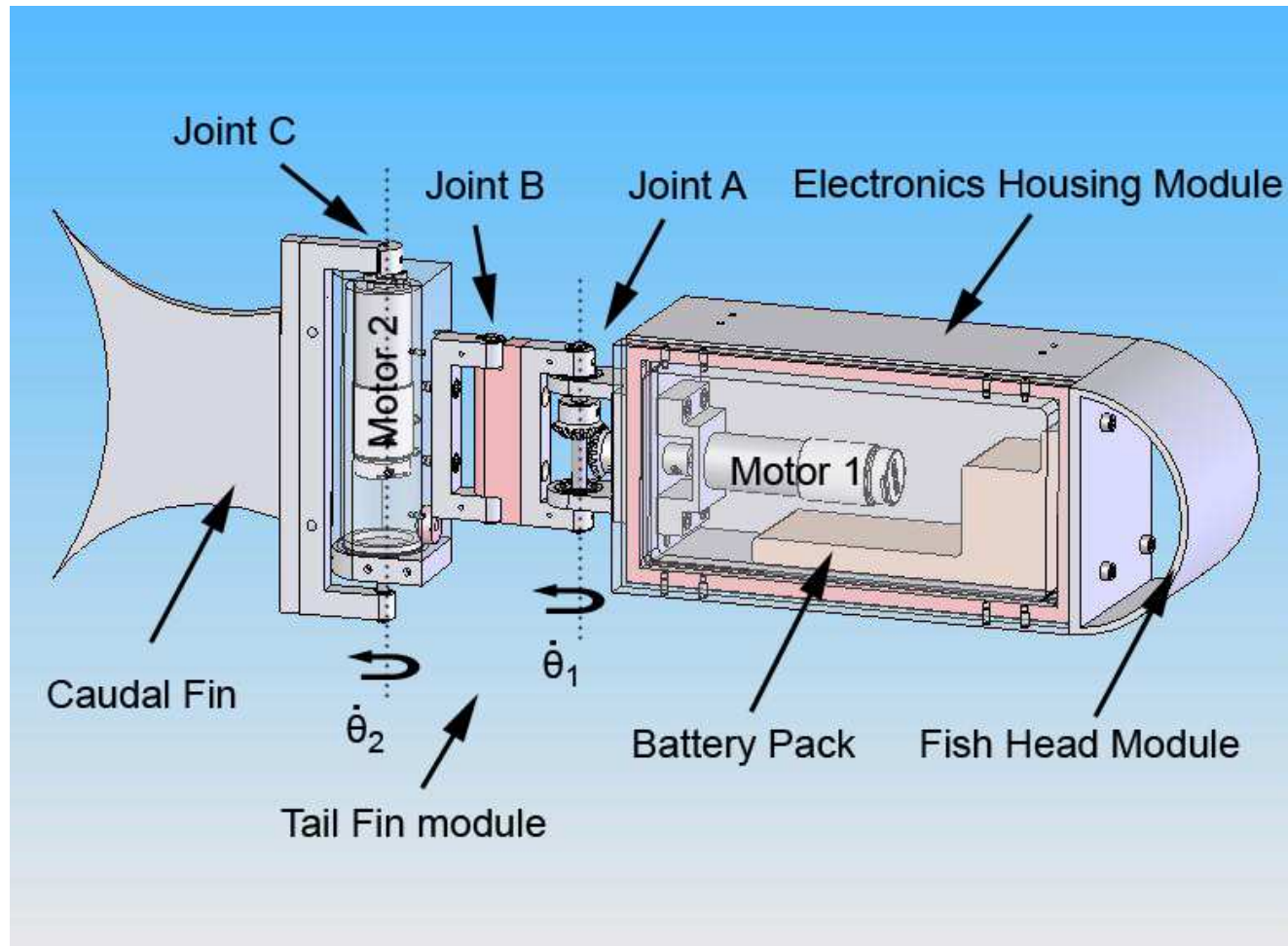

# Conceptual Design with Buoyancy Tank Module

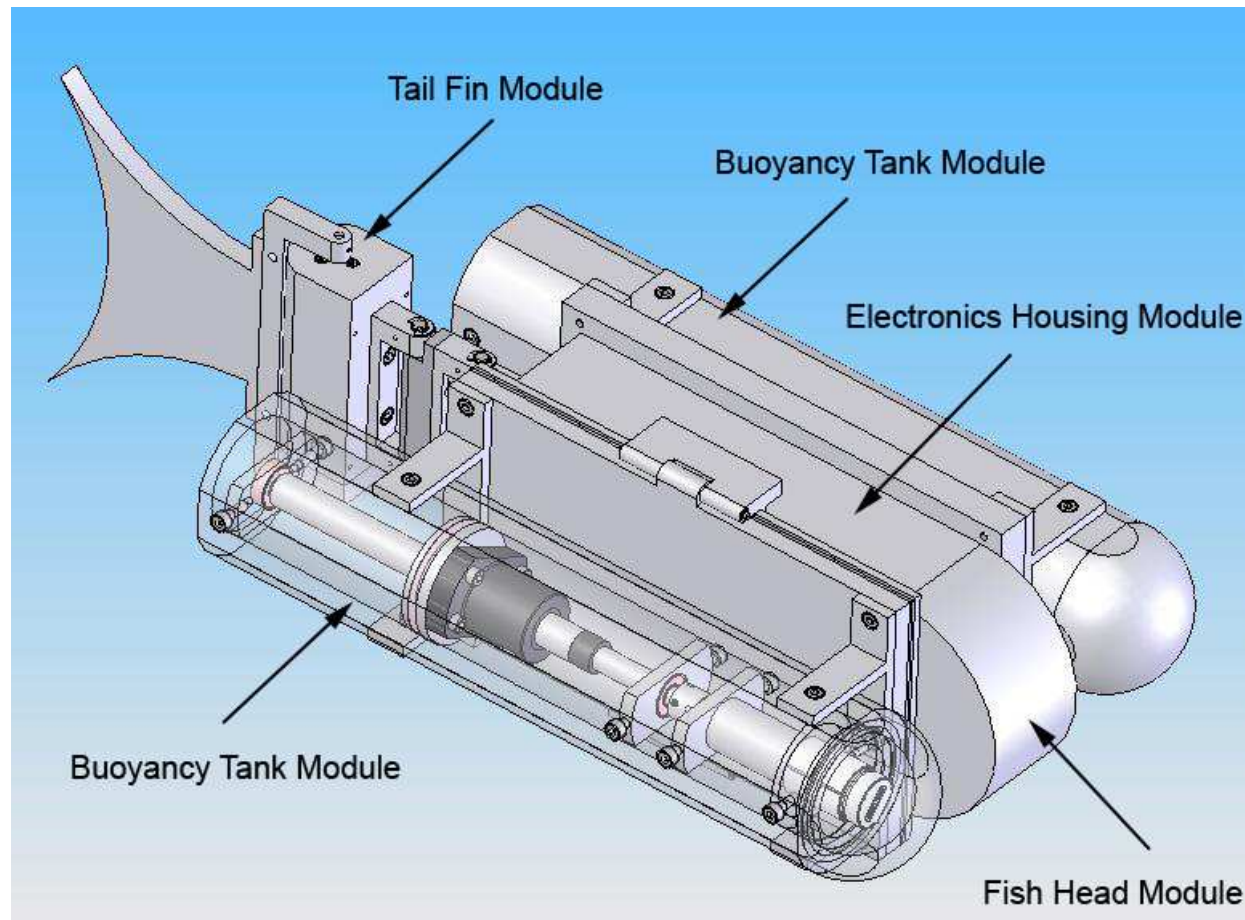

# Asian Arowana



# Arowana Robot

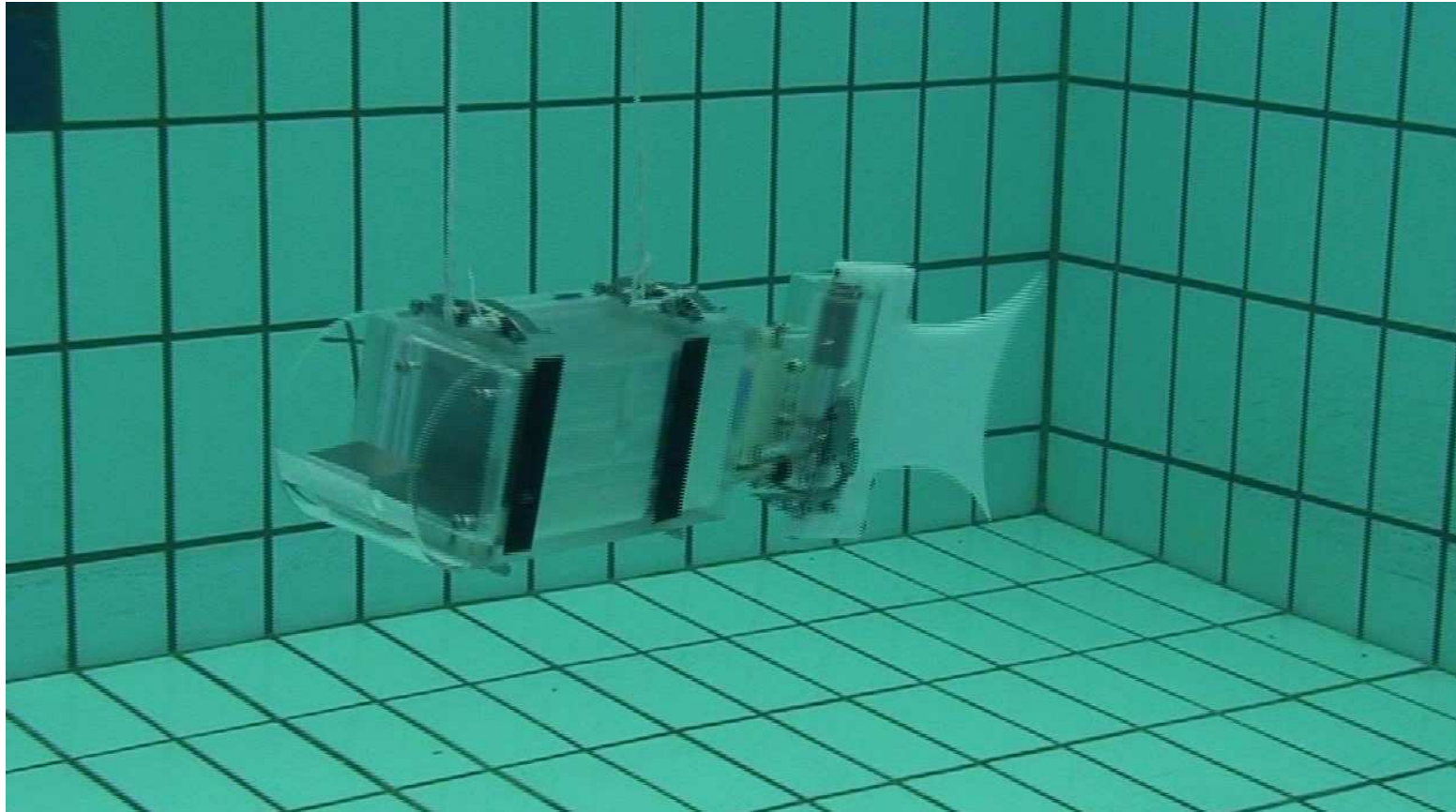

# **Arowana Robot – Lab and Swimming Pool Test**

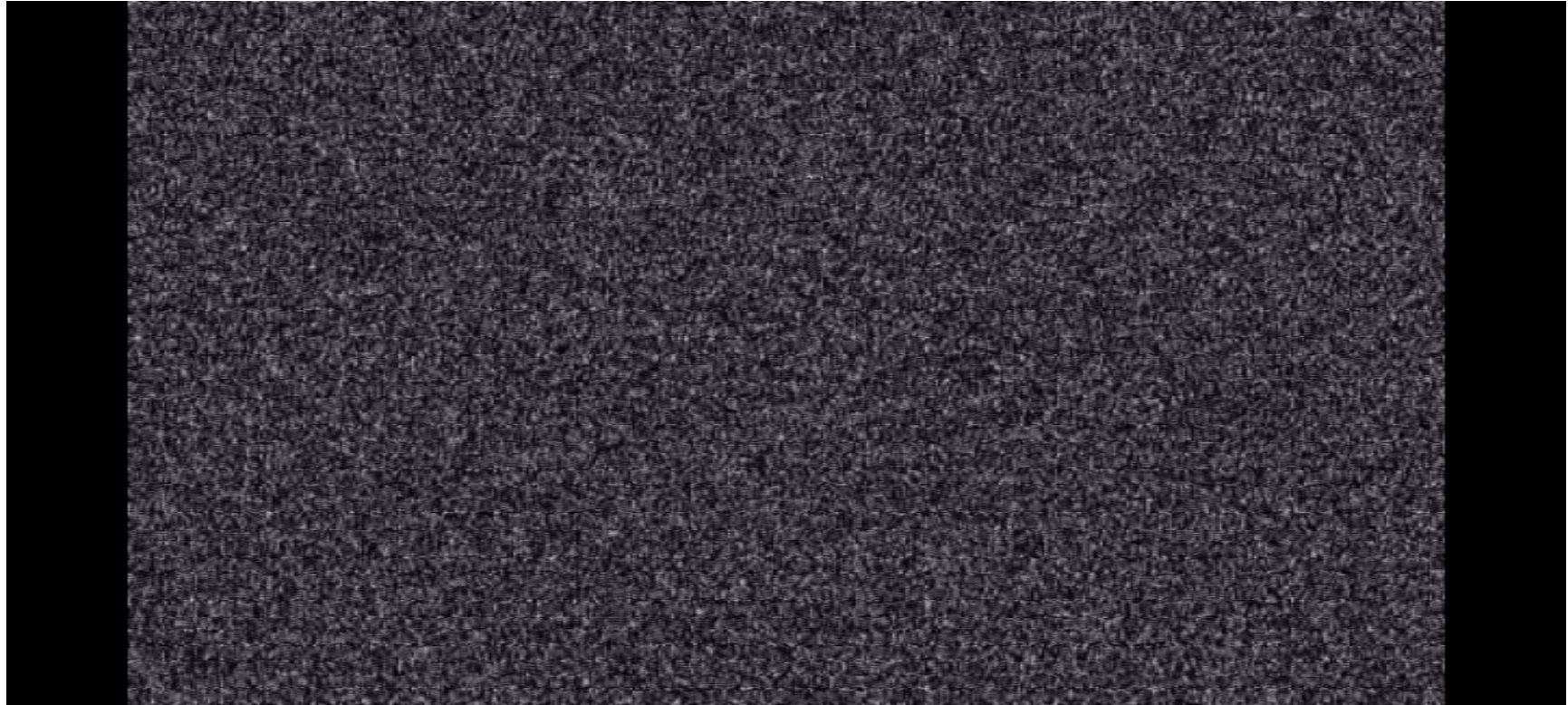

# Effects of Joint Angles on Fish Forward Velocity

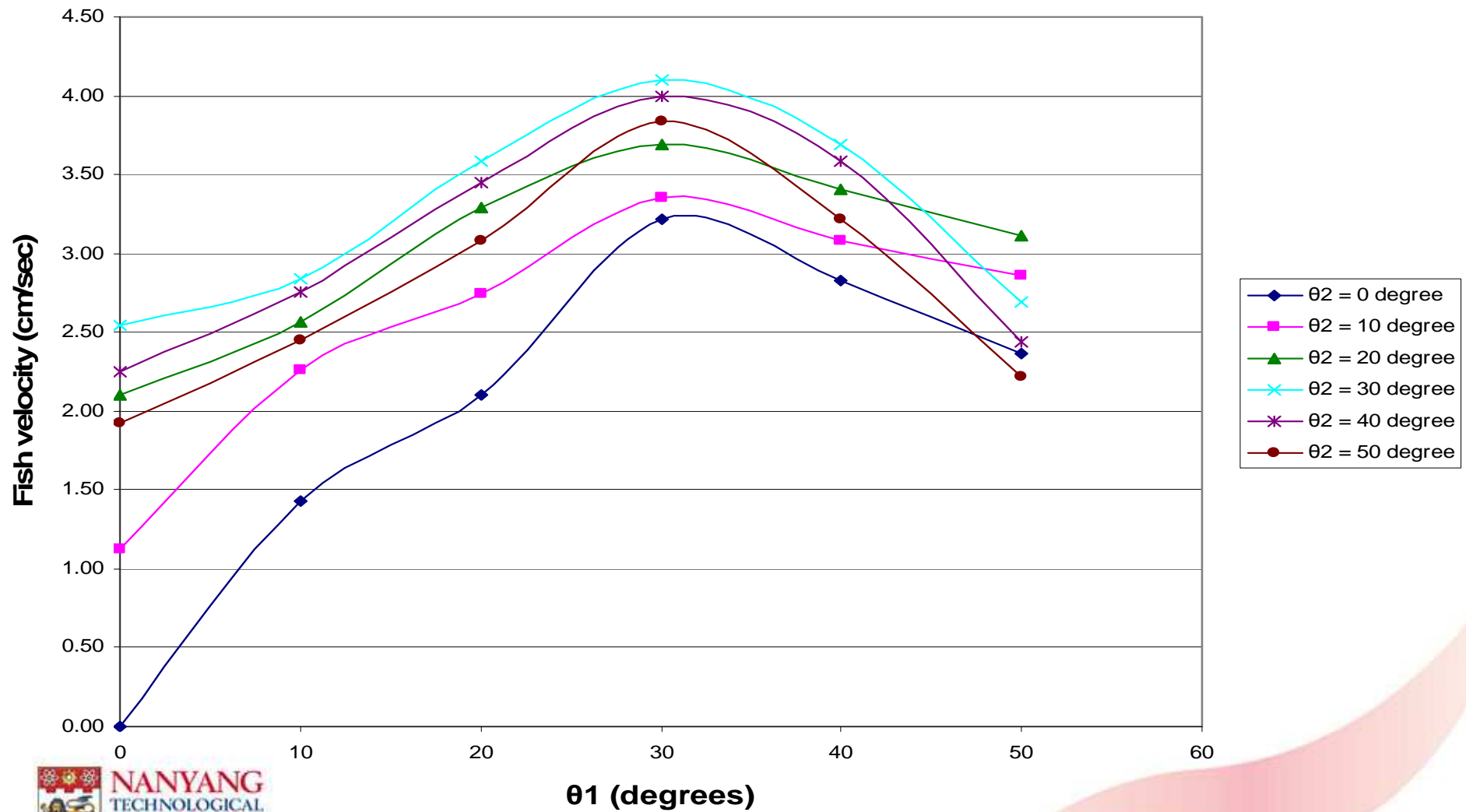

# Effects of Joint Angular Velocities on Fish Forward Velocity

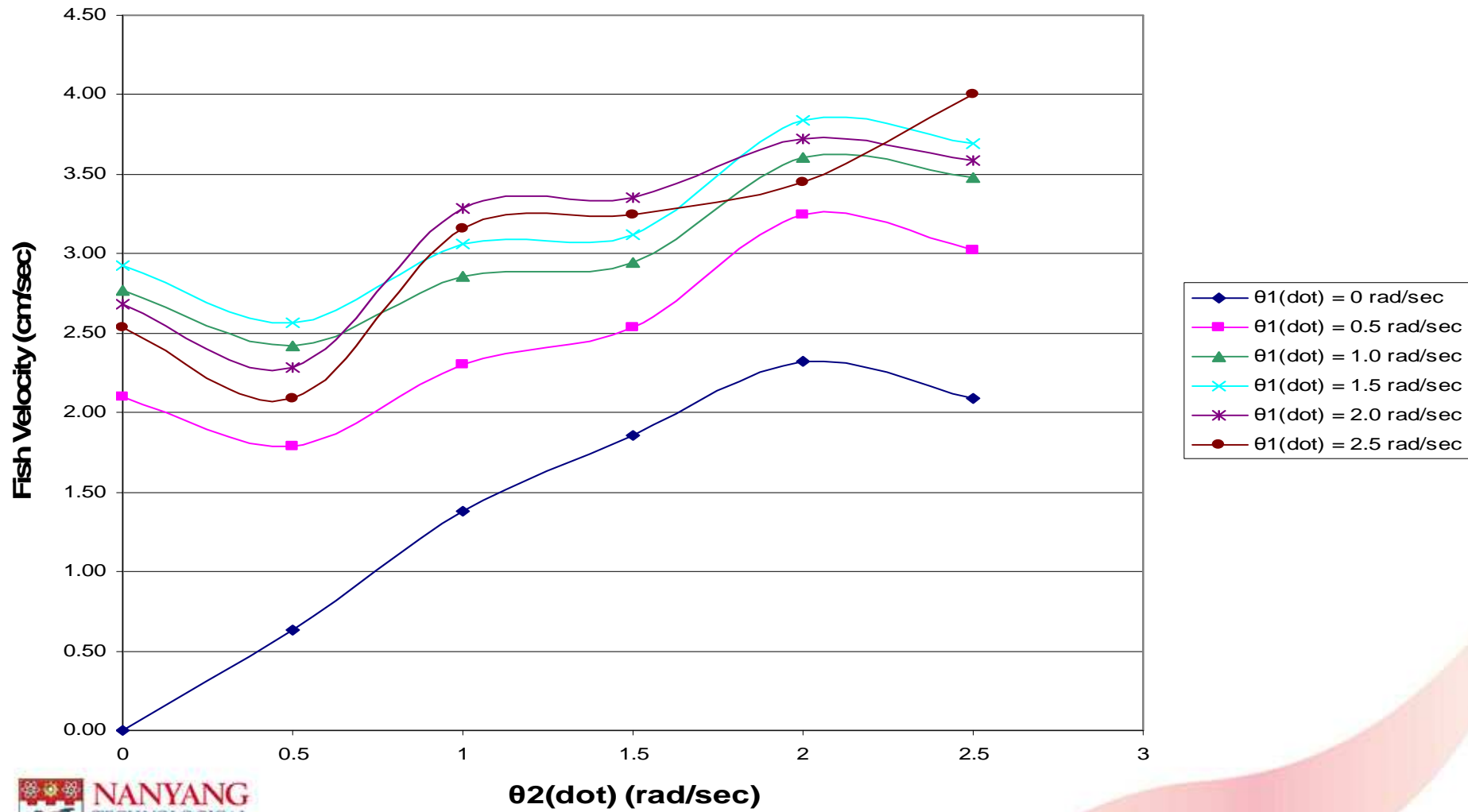

# Effects of Caudal Fin Sizes on Fish Forward Velocity

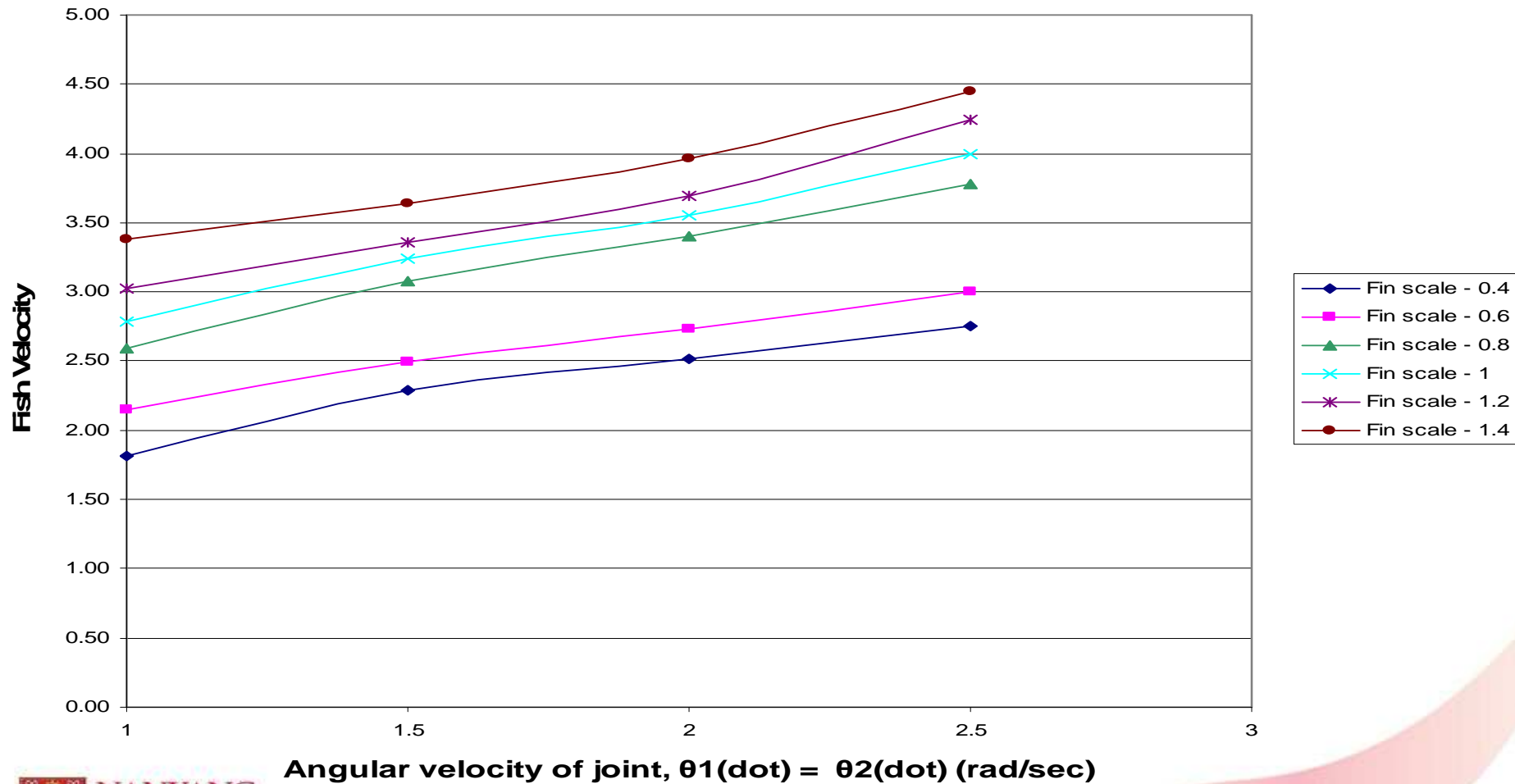

# Effects of Caudal Fin Material on Fish Forward Velocity

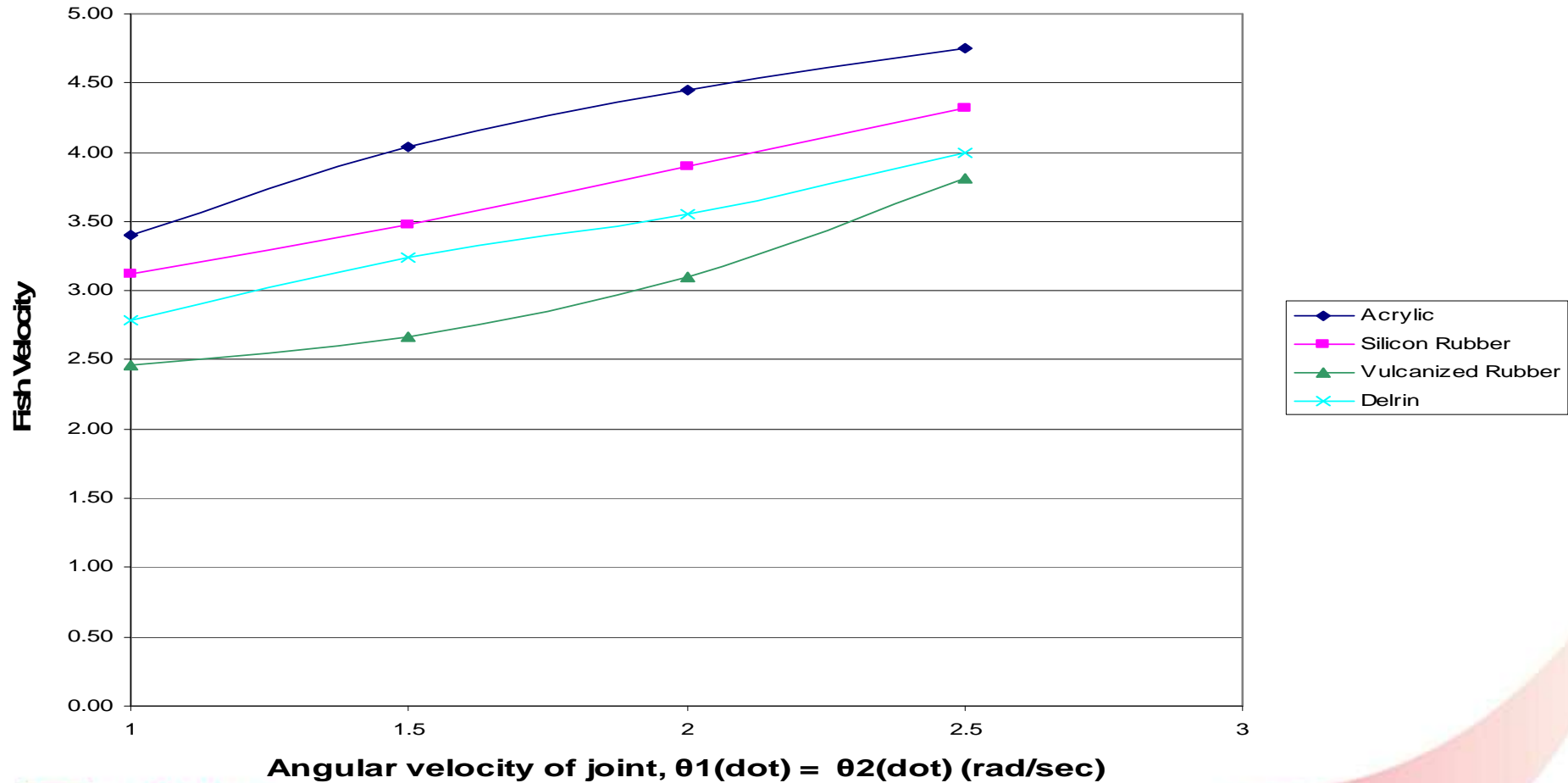

# Future Applications & Conclusion



- Surveillance
- Inspection
- Spying
- De-mining
- Sea Bed Mapping
- Team Mission
- Biological Research

**Issues:** *Compactness, speed, communication, control, etc.*

# Acknowledgements

- Capstone Design Education Center, Seoul National University of Technology (Korea)
- Ministry of Commerce, Industry and Energy (Korea)
- School of Mechanical and Aerospace Engineering, Nanyang Technological University (Singapore)
- Robotics Research Center, Nanyang Technological University
- Mr. Andre Willy, Mr. Aw Wai Leong

